

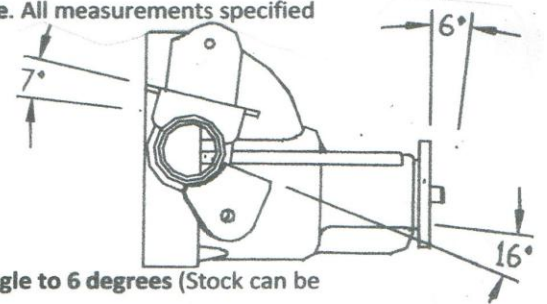

ECGS FORD 8.8 BRACKET INSTRUCTIONS (ZJ AXLE)

1. Check Housing For Straightness.
2. Remove all Original Brackets and clean all rust paint and debris from axle tubes.
3. Weld Cast center section to tubes if desired.
4. Verify axle width is **53.5" from inside flange to inside flange**. All measurements specified assume this measurement is correct.

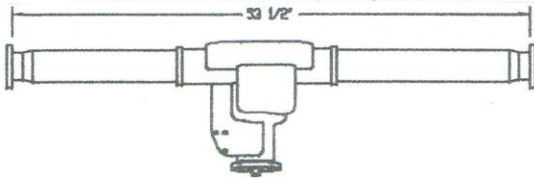

5. Support axle in suitable fixture (3 jack stands) Set pinion angle to **6 degrees** (Stock can be adjusted if desired).
6. Tack lower control arms **6.25" from inside flange** at a **16 degree down angle** on top surface of bracket.
7. Tack upper control Arm brackets **12" from inside flange vertical (90 degrees)**

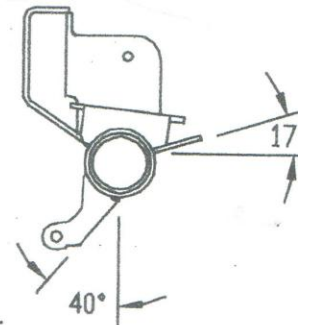
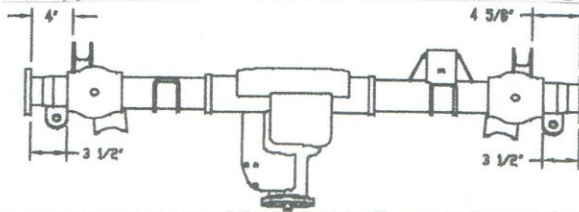

8. Tack Spring Plates **3.5" from inside flange 7 degree down angle**.
9. Tack weld Sway bar mount **Flush with bottom of Spring Perch 17 degree angle Up**.
10. Tack weld shock mounts **40 degree angle. From flange: Passenger Side 4" , Driverside 4.625"**

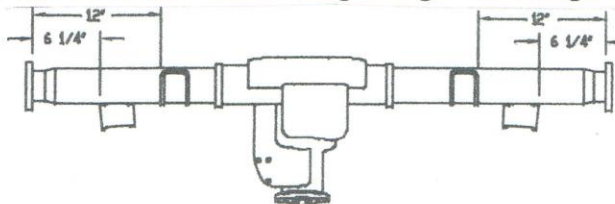

11. Tack Track bar mount to tube and top of D-side UCA. Install Bolt to insure Holes are aligned.
12. Install axle and insure proper fitment, Total Vehicle weight needs to be on springs to check correct fitment.
13. Remove axle and final weld.

Tech Notes: Make sure tack welds are strong enough to install axle but easy enough to grind off. After tack welding brackets check original axle and verify that center to center measurements are correct on UCA's, LCA's and spring Perch's.