

ONE PIECE AXLE KIT

Instructions for

Jeep CJ5, CJ7 & CJ8

with Timken® bearings

Extra care must be taken in order to assemble kit correctly. In order to help the other seal last longer, these axles are designed with a seal surface that is as close as possible to the diameter on the stock axles. This produces a very small step to press the bearing up against.

It is **VERY IMPORTANT** to only press the bearing up against the small step and not press the bearing onto the stepped-up surface that the outer seal rides on.

PRIOR TO ASSEMBLY:

- 1.) Identify your stock axles and compare them to the lengths in the table below (Dimension A) to be certain you have the correct axles for your applications. If your application is using a Power-Lok Limited slip (with two-piece side gear spines) this is the wrong length.
- 2.) Remove the brake backing plates that were used with your original axles. Make certain to mark the left and right backing plates, and note which way they are facing with respect to the parking brake cables.

Vehicle Model	Original Length Detention "A"	One-Piece Replacement Length, Detention "C"
'76-'83 CJ5	26-1/4"	23-1/4"
'76-'81 CJ7	29-1/4"	26-1/4"
'82-'86 CJ7	28-1/2" 31-1/2"	25-3/8" 28-1/4"

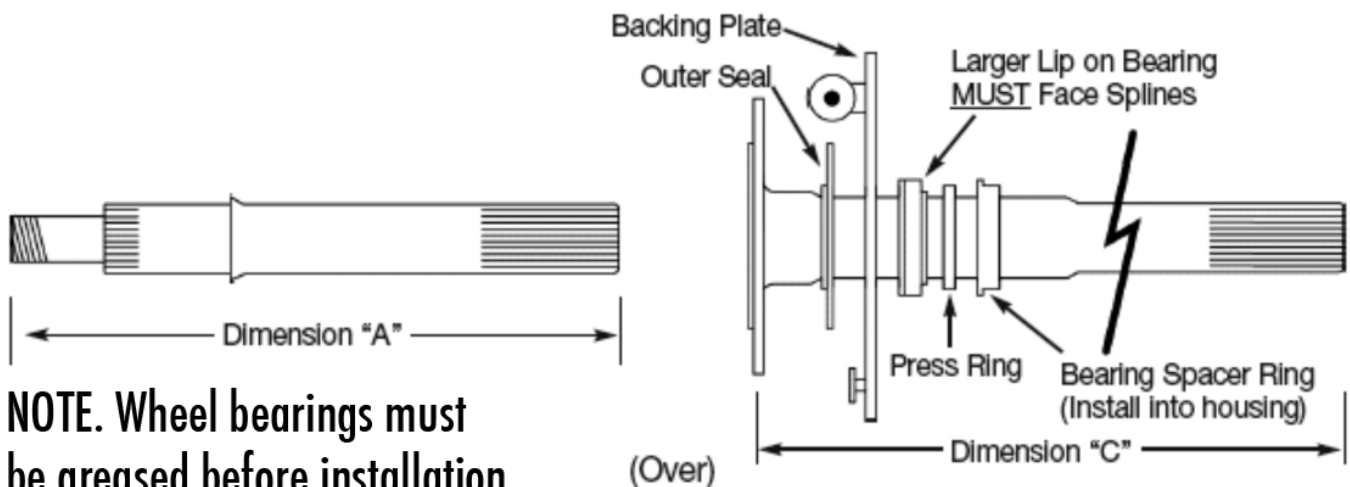
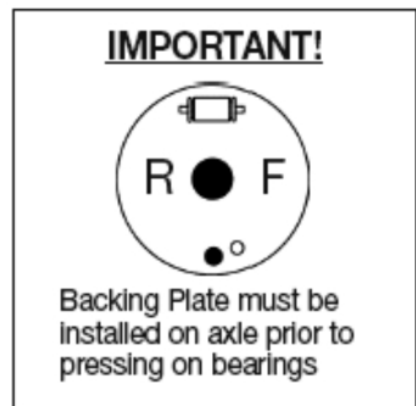

NOTE. Wheel bearings must be greased before installation

ONE PIECE AXLE KIT

(continued)

ASSEMBLY:

- 1.) Oil or grease the outer seal lip then slide it on the axle shaft.
- 2.) Place the backing plate on the axle shaft after the outer seal. Make **CERTAIN** the backing plate is on the correct axle with the shoe side facing out and the parking brake cable headed in the right direction. Once the bearing is pressed on, the only way to remove the backing plate is to destroy the axle bearing and retainer.
- 3.) Install the inner axle seal into the housing until it stops against the inner most step.
- 4.) Install the bearing spacer into the housing making sure it does not press against the inner seal.
- 5.) Using the bearing assembly, check the fit of the bearing against the spacer. With the bearing all of the way in, the outer edge of the bearing needs to stick out 0.030." to 0.080" from the end of the housing. The bearing spacer may need to be ground in order to reach this dimension.
- 6.) After packing the bearings with high quality wheel bearing grease (white grease is NOT recommended), press the wheel bearing onto the axle. The larger lip goes toward the backing plate splines and the narrowed portion of the bearing assembly goes toward the backing plate. It is **VERY IMPORTANT** to **only press the bearing up against the small step** and not press the bearing onto the stepped-up surface that the outer seal rides on.
- 7.) After carefully pressing on the axle bearing, press the press ring (retainer) on until it bottoms out against the bearing assembly. It is **VERY IMPORTANT** **only press the bearing against the small step**. Due to the tighter than standard design, press ring may scrape along length of axle.
- 8.) Before installing the assembly into the housing, smear a little silicone sealer around the housing end, and between the backing plate and the outer seal flange.
- 9.) Tighten all of the bolts and finish assembling the rest of the brake lines and cables.

